

TURNERS ANONYMOUS

An Association of Wood Turners in Western Pennsylvania

NEWSLETTER

No 91

December 2005

President Craig Smith 412 996 6666	Vice-President Ted Owen 724 625 1038	Treasurer Dave Beringer 412 655 8524	Secretary Tim Janeway 412 761 3518
--	--	--	--

A Very Happy Christmas to all of You'ns

NEXT MEETING:

Saturday,

Location: Center for Contemporary Crafts,
101 Smallman Street in the Strip District

Time: 10.00 am.

This will be our annual **Christmas Party** With an opportunity to show off some of your best work to members and friends. (please remember to have a card beside each piece indicating your name, species of wood, finish applied etc so that folks with questions or comments can approach you)

A Lathe will be raffled. Each person attending will receive 1 ticket and more can be purchased for \$ 1.00 or 6 for \$ 5.00.

We will also be giving away tickets (with a different colour) for each top donated and 2 tickets for each car. There will be a drawing with the winners getting one of the turnings produced by Stuart Batty during his recent demonstrations.

We still have wheels and axles available for cars which will be handed out as needed at the meeting. So, if you've turned some cars that are immobile bring them along for some supercharged input from the drill press and 7/32" diameter drill bit that will be on hand with suitably qualified mechanic.

Lathes are available and can be up and running to demonstrate or produce yet more tops

shown, only to discover problems that are difficult to solve on your own. This month we will be demonstrating several of those problem areas from previous demonstrations. If you want us to cover a specific point please tell a committee member and we will try to cover it at this meeting

LAST MEETING.

Everyone got something from **John Colombini's** presentation. At first there were OOHs and AAHS as the beautiful and intricate turned items were visible to folks that had not seen them before. Then came the puzzled looks and comments like "How on earth does he do that" John proceeded to explain his methods and pointing out that design, cutting parts and assembling all took even more time and care than the turning. Components and diagrams were passed around the audience and myriad questions were neatly fielded and answered.

Several members felt that they would not have the patience (or skill) to do this type of work but others were like bees round a honey pot at the end of the meeting asking John many questions. Thank you John for a very well constructed and enjoyable meeting.

The Tops Meet

Our Top Turners and beginners enjoyed an evening at **Jack Brown's Shop** on December 1st. In spite of the distractions of Diane's cookies and coffee, plus a lot of friendly conversation, we were able to produce a quantity of tops on the five available lathes. Jack had prepared a box of blanks which could be popped into the chucks and turned simply or in a complex colourful manner. Tuition was available as needed and we hope that you will be bringing your tops to our Christmas party.....Don't forget that Raffle Tickets will be given in exchange for tops..

FUTURE MEETINGS

January 21st Several Lathes will be used to demonstrate techniques needed to produce components for our **Collaborative Challenge** and if you want to try your hand with an experienced turner to help, this is your chance.

February 18th **Multiple Demonstrations.** How often have you attended a demonstration by one of those experts for whom nothing ever goes wrong; and then tried to duplicate what he had

TURNERS ANONYMOUS

NEWSLETTER

*The American Association of Wood Turners,
(The A.A. W.)*

This is our parent organisation and if you are not already a member please make a new year resolution to do so. Only then can you enjoy the bi-monthly journal with full colour illustrations of work by world famous turners, read articles of simple work that you as a beginner can turn. Also don't forget that unless you are an AAW member, you cannot demonstrate at any public demonstrations arranged by Turners Anonymous.

If you are already a member, congratulations, and continue to enjoy all that membership offers. Only by looking in the membership directory can you find the addresses for wood turners that you could contact in Iceland or New Zealand during your next vacation.

2006 Vacations.

There are several locations in Europe for wood turning classes, also Museums and Churches with outstanding wood turnings from earlier periods.

Are there any members who would be interested in a group tour next summer to visit some of these sites and take a course in some aspect of wood turning? If you are worried about the language, Sheila or I could help with translations where required. Let me know if you might be interested. John Bridges 724 625 9348

Editorial.

Let's imagine a family consisting of MA, PA and TA sitting round the fire on a Christmas Eve busy writing their Christmas Wish lists. TA being the Turners Anonymous Wood turning Club, They will all be rushing down on Christmas morning to see if Santa has brought them any or many of the things that were on their list. Let's cheat for a moment and look over TA's shoulder and see what is on his wish list..

First will be a hope for more guardians, and active ones at that. To help him grow and remain active more members need to get in on the act and help set up programmes. A treasurer to look after his finances, a specialist to look after his legal affairs plus nursemaids to bring him coffee and donuts or plan activities. His parents

who created him 20 years ago need help and alone cannot cope with this rambunctious teenager any longer.

Second on the list is for more vocal members who will tell the guardians what they like and don't like. Silence leads to wondering as to whether the programmes provided are what members actually want or not.

Third could be (his writing is hard to read, especially where the Strawberry Jam got smeared over it) a request for more young playmates. He suggests that the club should do more to encourage and teach more kids to turn wood. He read in the AAW Journal how other clubs are teaching kids and he is sad that now Jessica Henry has gone to College and no longer attends our meetings he sees few young faces.

Fourth on the list is for more members to open their shops to small groups of (two three or even one) members so that special skills or even basic skills can be shared or demonstrated in comfort on a cold winter's night

Fifth is a wish for more nurseries and playrooms. TA says that although he enjoys the big monthly meetings, he would like to see more, smaller, satellite meetings where beginners can practice and learn or experienced turners can see or demonstrate new techniques.

(continued on next page)

Sixth is a request for more members to use electronic mail for their Newsletters *Editor's note.*

Ta has problems spelling these newfangled words)

If you insist on the Club spending 37 cts on you each month you will continue to get black and white copies; whereas if you download a copy from the web it will come in glorious Technicolor. The choice, says Ta, is yours.

Come on! Help Santa to provide Ta with all he needs to flourish. Have a Very happy New year

TURNERS ANONYMOUS

NEWSLETTER

A Christmas Tree Ornament you could make

There is still plenty of time to make this for your tree, or several to give away to family, friends or neighbours. All you need is a short 3" length of 2" x 2" hardwood, but not too hard and I find Cherry ideal for this miniature Lantern.

All four sides should be square and planed to a smooth finish. Actual dimensions are not important but it must be square with equal sides.

Mount it between centres and turn the top as shown in the drawing below or to any shape you choose, not forgetting that the original lamp will be hot and need ventilation. Don't worry about the marks made by the drive center, there will be few earthworms gazing upwards at your lantern! Or you could face it off.

Remove the lantern from the lathe and clamp it centrally on your drill press to drill and hole using a 1¼" Forstner bit. Drill right through and then turn the lantern 90° and repeat the process.

Take a short length of 1/8" diameter dowel rod, place it in a Drill Chuck mounted in the head stock of your lathe. Turn a "Flame" at the end.

Drill a 1/8" hole in the base of the lantern and push the Candle up into this hole. Before doing this colour the flame yellow and the body of the candle any colour of your choice. (I use wax crayons for this)

Fit a very small screw eye into the top and Hey Presto! you can once again give pleasure to someone from your lathe

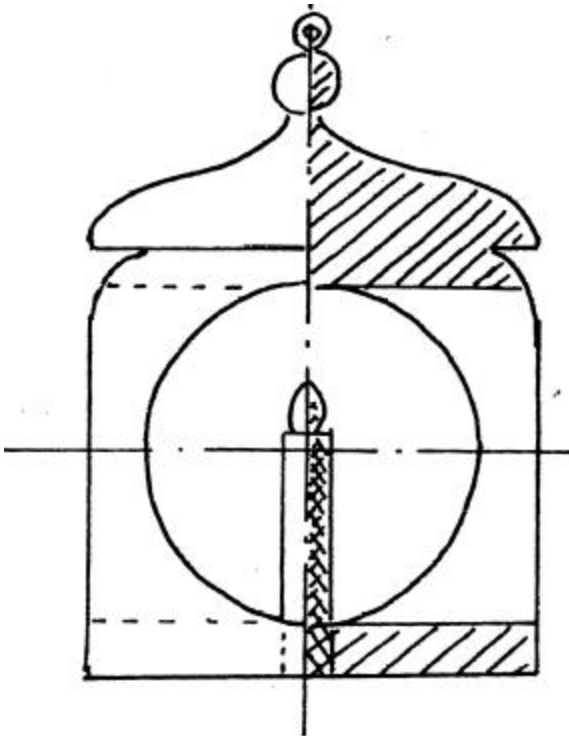

TURNERS ANONYMOUS

NEWSLETTER

Woods for Turning.

Christmas is the season when we sing about the Holly and the Ivy.

Holly is a very white, fine grained wood and is often used for Inlay work, or for some special fine turnings there the close even grain and colour are appreciated. It is however very susceptible to decay and unless care is taken in conversion from the log will contain blue or black streaks. We normally think of Holly as being a bush rather more than a tree, but, as a teenager in Wales remember felling one with a diameter in excess of 12".

A similar wood, but one with rather more of a yellow colour is Boxwood which grows abundantly on the chalk downs in the South of England. It was a favourite wood of the turners of trees in the 19th Century. It is famous for being a stable wood and was used for wooden rulers and straight edges used by draftsmen. In 1815 Box wood was sold from Box Hill in Surrey for \$20,000 which was a lot of money in those days. It is not stable and French turners kept it in a damp cellar for 5 years and then soaked in water before boiling it. They kept it in bran until ready to put on their lathe. Most wooden Chess sets are of Boxwood and Ebony.

But the story does not end there since there are substitutes waiting in the wings:- Maracaibo, Kamassi, Knysna, Indian and Siamese Boxwoods are similar but not as good as the legitimate Buxus sempervirens as found in formal European gardens.

American Dogwood has similar properties but lacks the startlingly white colour

I have never tried turning Ivy, although occasionally a large 4" diameter stem can be found.

I have however turned a goblet from American wild grape about 4 " diameter and no one could guess which wood had been used.

Each year sees more organisations advertising wood blanks for turning and the choice of species available increases. Many of these are not present in the traditional timber trade, but have properties such as colour, grain or defects of peculiar interest to turners. Turners are a species of human beings that can't go for a walk in the country or drive past a fallen tree without

examining it and trying to take a sample home to see if it will turn. Experiment by all means, but do examine it well before chucking it on the lathe or chucking it out. Seriously ask yourself is this specie what I really want?

Christmas Wish Lists.

If you are new to turning and want to put a Lathe on your List you are probably wondering what sort of lathe to ask for. The first question to ask yourself is "What do I want to Turn?". Whilst Big lathes can turn small objects there is no need for a big lathe if you only want to turn pens. Probably one of the Mini-lathes now becoming popular would be a good fist bet. If you want to turn bowls you might want to start with a bigger lathe, but you could of course practice on a small scale to start with; we see only too many first time turners wanting to turn something BIG. If you are one of these please, please make sure that you can reduce the speed of your lathe to a minimum.

The same applies to accessories and tools that you hope will appear in your stocking. Decide what you want to turn and confine your list to those items that really are used for turning your chosen objects. A Ring Tool is of little use for turning Christmas Ornaments whereas a skew Chisel is of little use for hollowing vessels.

If you get yet another tie that you don't want for Christmas you can give it to the Salvation Army. If you get a tool that you don't want advertise it in our Newsletters.

TURNERS ANONYMOUS

NEWSLETTER

For Sale:

Delta 14in band saw 3/4 horse power
open stand, delta riser kit, delta metal mobile
base, fasttrak fence, cool blocks
extra blades \$475.00
Call me at work or home
w.412-647-5042
h.412-751-1562 Ron Fontana

Kiln Dried Hard and Soft woods from **Steve Morovich** before or after the meeting or call him at **724 341 1980**.

Cherry, Oak, Sassafras and Walnut Boards or Turning blanks. Logs sawn to your dimensions. I have several 3" thick Walnut crotches left; air dried for three years also Cherry and Walnut up to 22" wide. **John Bridges 724 625 9348**

Editor:

*John Bridges
1743, Old State Road.
Gibsonia Pa 15044
brimor@aol.com*